

General Description

TD1464 is a monolithic asynchronous buck regulator. The device provides 1.5A of continuous load current over a wide input voltage of 9V to 40V. It uses current mode control to regulator the output voltage and provides fast transient response.

Requiring a minimum number of external components, these regulators are simple to use and include internal frequency compensation, and a fixed-frequency oscillator. Anti-ring function is to reduce the influence of EMI.

This device, available in a SOP-8 package, provides a very compact system solution with minimal reliance on external components.

Features

- Internal Power MOSFET
- 1.5A continuous output current
- Up to 90% efficiency
- Input voltage range: 9V to 40V
- Fixed 150kHz frequency internal oscillator
- Current limit protection
- Anti-ringing for lower EMI
- Over temperature protection
- SOP-8 package

Applications

- Simple high-efficiency step-down regulator
- Efficient pre-regulator for linear regulators
- On-card switching regulators
- Positive to negative converter
- Battery charger

Pin Configurations

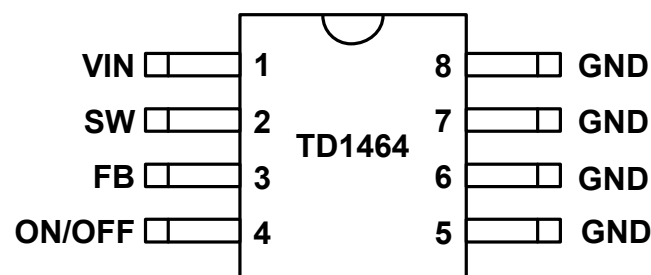

Figure1 Pin Configuration of TD1464(Top View)

1.5A 150KHz PWM Buck DC/DC Converter TD1464

Pin Description

Pin Number	Pin Name	Description
1	VIN	Power Input. In supplies the power to the IC, as well as the step-down converter switches. Drive IN with a 9V to 40V power source. Bypass IN to GND with a suitably large capacitor to eliminate noise on the input to the IC. See Input Capacitor.
2	SW	Power Switching Output. SW is the switching node that supplies power to the output. Connect the output LC filter from SW to the output load.
3	FB	Feedback Input. FB senses the output voltage to regulate that voltage. Drive FB with a resistive voltage divider from the output voltage. The feedback threshold is 1.23V.
4	ON/OFF	Enable Input. ON/OFF is a digital input that turns the regulator on or off. Diver ON/OFF low to turn on the regulator; drive it high to turn it off.
5,6,7,8	GND	Ground.

Ordering Information

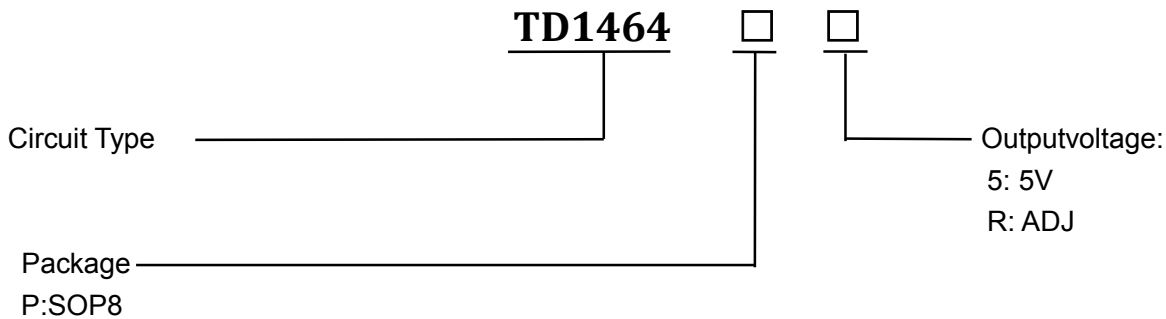

1.5A 150KHz PWM Buck DC/DC Converter TD1464

Function Block

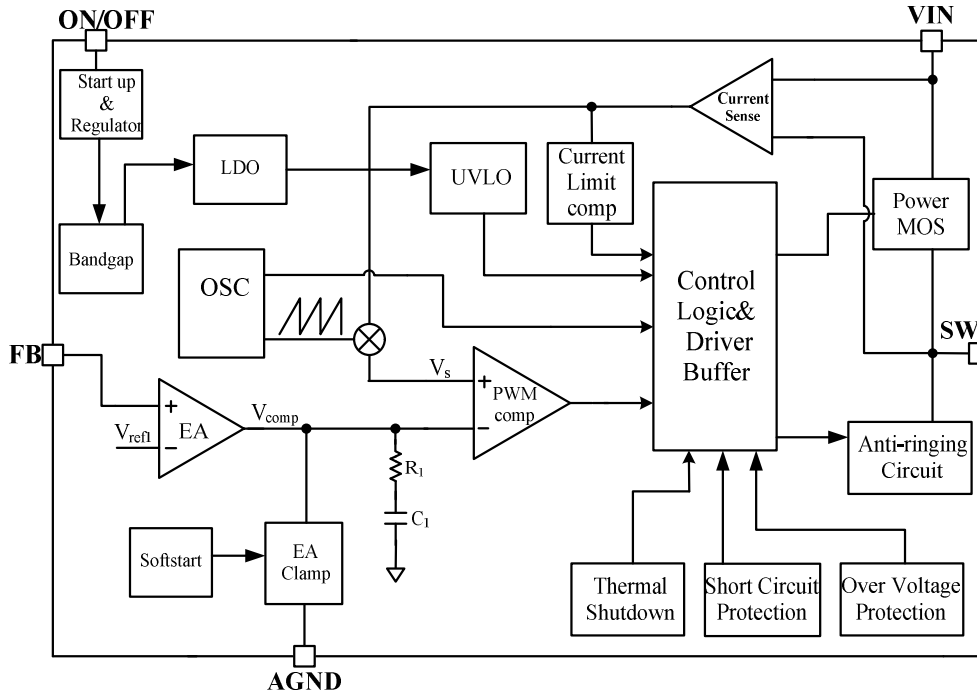

Figure 2 Function Block Diagram of TD1464

Absolute Maximum Ratings

Parameter	symbol	Value	Unit
Input Voltage	V_{IN}	-0.3 to 42	V
Feedback Pin Voltage	V_{FB}	-0.3 to 5	V
ON/OFF Pin Voltage	V_{EN}	-0.3 to 5	V
Output Pin Voltage	V_{SW}	-0.3 to $V_{IN}+0.3$	V
Power Dissipation	P_D	Internally limited	mW
Operating Junction Temperature	T_J	150	°C
Storage Temperature	T_{STG}	-65 to 150	°C
Lead Temperature	T_{LEAD}	260	°C
ESD (HBM)		2000	V
MSL		Level3	
Thermal Resistance-Junction to Ambient	$R_{\theta JA}$	23	°C/W
Thermal Resistance-Junction to Case	$R_{\theta JC}$	3.5	°C/W

Recommended Operating Conditions

Parameter	Symbol	Min.	Max.	Unit
Input voltage	V_{IN}	9	40	V
Output voltage	V_{out}	1.23		V
Converter output current	I_{out}	0	1.5	A
Operating junction temperature	T_J	-40	125	°C
Operating ambient temperature	T_A	-40	85	°C

Electrical Characteristics

$V_{IN}=12V$, $T_A=+25^{\circ}C$, unless otherwise noted

Parameter	Symbol	Condition	Min	Typ	Max	Units
TD1464PR	V_{FB}	$9V \leq V_{IN} \leq 40V$	1.200	1.23	1.26	V
TD1464P5	V_{OUT}	$9V \leq V_{IN} \leq 40V$	4.8	5.0	5.2	V
Shutdown Supply Current		ON/OFF=5V	-	-	10	uA
Quiescent current	I_Q	ON/OFF=0V; $V_{FB}=1.5V$	-	3	4.5	mA
Oscillation Frequency	F_{OSC1}	$V_{FB} > 0.3$	120	150	180	kHz
Highside Switch On Resistance	$R_{DS(ON)}$		-	400	-	mΩ
Current Limit	I_L	Peak output current	-	2.3	-	A
Maximum Duty Cycle	D_{MAX}		-	-	98	%
ON/OFF Threshold voltage	V_{IL}	Low(Regulator ON)	-	0.9	-	V
	V_{IH}	High(Regulator OFF)	-	1.0	-	V
Input Under Voltage Lockout Threshold		V_{IN} Rising	-	8.3	-	V
Input Under Voltage Lockout Threshold Hysteresis			-	500	-	mV
Thermal Shutdown			-	160	-	°C

1.5A 150KHz PWM Buck DC/DC Converter TD1464

Typical Application Circuit

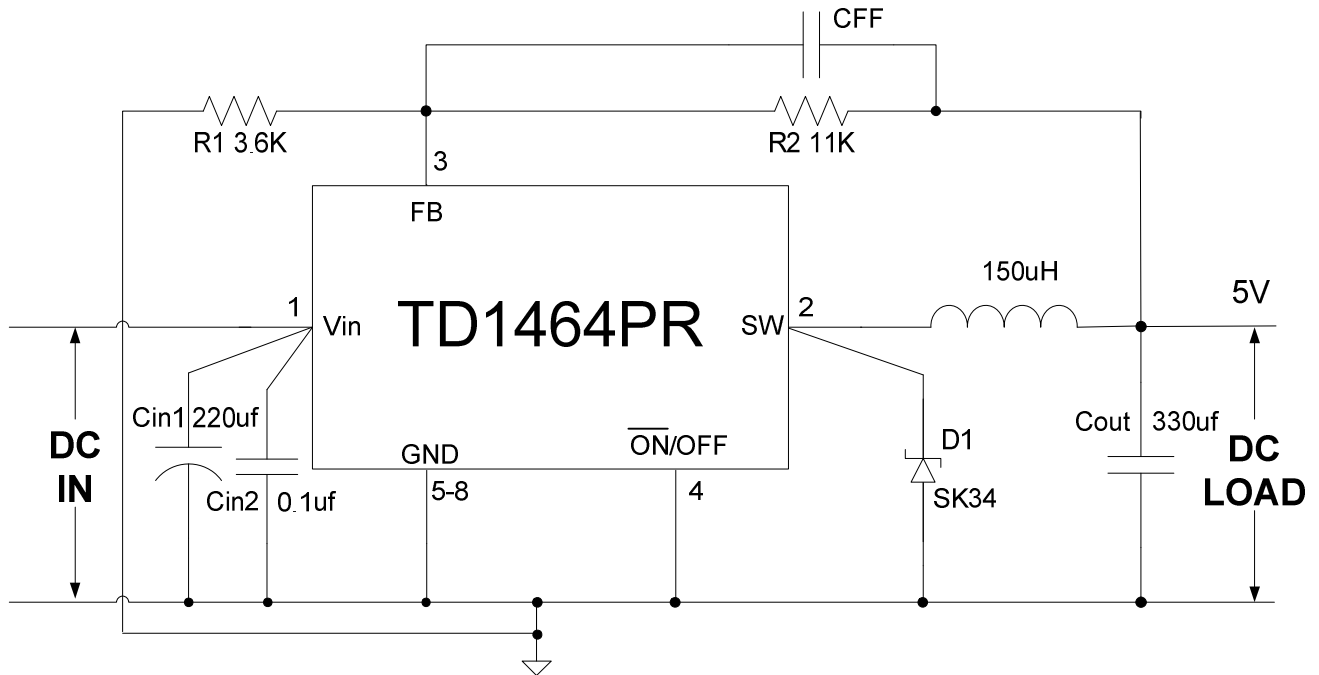

Figure 3 Typical Application of TD1464PR

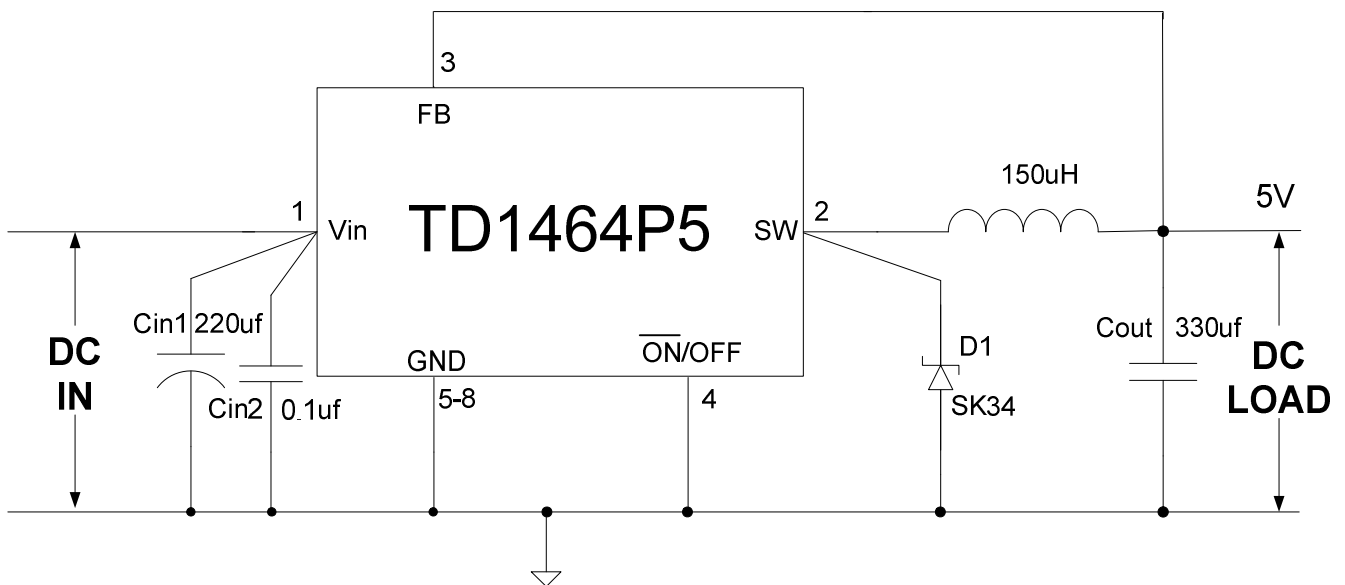

Figure 4 Typical Application of TD1464P5

Function Description

The TD1464 regulates input voltages from 6V to 40V down to an output voltage as low as 1.23V, and supplies up to 1.5A of load current.

The TD1464 uses current-mode control to regulate the output voltage. The output voltage is measured at FB through a resistive voltage divider and amplified through the internal trans-conductance error amplifier. The output voltage of the error amplifier is compared to the switch current (measured internally) to control the output voltage.

Setting the Output Voltage

The output voltage is set using a resistive voltage divider connected from the output voltage to FB. The voltage divider divides the output voltage down to the feedback voltage by the ratio:

$$V_{FB} = V_{OUT} \times \left(\frac{R_2}{R_1 + R_2} \right)$$

Thus the output voltage is:

$$V_{OUT} = 1.23 \times \left(\frac{R_1 + R_2}{R_2} \right)$$

Inductor

The inductor is required to supply constant current to the load while being driven by the switched input voltage. A larger value inductor will result in less ripple current that will in turn result in lower output ripple voltage. However, the larger value inductor will have a larger physical size, higher series resistance, and/or lower saturation current. A good rule for determining inductance is to allow the peak-to-peak ripple current to be approximately 30% or the maximum switch current limit. Also, make sure that the peak inductor current is below the maximum switch current limit.

The inductance value can be calculated by:

$$L = \frac{V_{OUT}}{f_s \times \Delta I_L} \times \left(1 - \frac{V_{OUT}}{V_{IN}} \right)$$

Where V_{OUT} is the output voltage, V_{IN} is the input voltage, f_s is the switching frequency, and ΔI_L is the peak-to-peak inductor ripple current.

Choose an inductor that will not saturate under the

maximum inductor peak current, calculated by:

$$L_P = I_{LOAD} + \frac{V_{OUT}}{2 \times f_s \times L} \times \left(1 - \frac{V_{OUT}}{V_{IN}} \right)$$

where I_{LOAD} is the load current.

The choice of which style inductor to use mainly depends on the price vs. size requirements and any EMI constraints.

Input Capacitor

The input current to the step-down converter is discontinuous, therefore a capacitor is required to supply the AC current while maintaining the DC input voltage. Use low ESR capacitors for the best performance. Ceramic capacitors are preferred, but tantalum or low-ESR electrolytic capacitors will also suffice. Choose X5R or X7R dielectrics when using ceramic capacitors. Since the input capacitor (C_1) absorbs the input switching current, it requires an adequate ripple current rating. The RMS current in the input capacitor can be estimated by:

$$I_{C1} = I_{LOAD} \times \sqrt{\frac{V_{OUT}}{V_{IN}} \times \left(1 - \frac{V_{OUT}}{V_{IN}} \right)}$$

The worst-case condition occurs at $V_{IN}=2V_{OUT}$, where $I_{C1} = I_{LOAD}/2$. For simplification, use an input capacitor with a RMS current rating greater than half of the maximum load current. The input capacitor can be electrolytic, tantalum or ceramic. When using electrolytic or tantalum capacitor, be placed as close to the IC as possible. When using ceramic capacitors, make sure that they have enough capacitance to provide sufficient charge to prevent excessive voltage ripple at input. The input voltage ripple for low ESR capacitors can be estimated by:

$$\Delta V_{IN} = \frac{I_{LOAD}}{C_1 \times f_s} \times \frac{V_{OUT}}{V_{IN}} \left(1 - \frac{V_{OUT}}{V_{IN}} \right)$$

where C_1 is the input capacitance Value.

Output Capacitor

The output capacitor (C_2) is required to maintain the DC output voltage. Ceramic, tantalum, or low ESR electrolytic capacitors are recommended. Under typical application

1.5A 150KHz PWM Buck DC/DC Converter

TD1464

conditions, a minimum ceramic capacitor value of 20μF is recommended on the output. Low ESR capacitors are preferred to keep the output voltage ripple low. The output voltage ripple can be estimated by:

$$\Delta V_{OUT} = \frac{V_{out}}{f_s \times L} \times \left(1 - \frac{V_{out}}{V_{in}}\right) \times \left(R_{ESR} + \frac{1}{8 \times f_s \times C2}\right)$$

Where C2 is the output capacitance value and RESR is the equivalent series resistance (ESR) value of the output capacitor.

When using ceramic capacitors, the impedance at the switching frequency is dominated by the capacitance which is the main cause for the output voltage ripple. For simplification, the output voltage ripple can be estimated by:

$$\Delta V_{OUT} = \frac{V_{OUT}}{8 \times f_s^2 \times L \times C2} \times \left(1 - \frac{V_{OUT}}{V_{IN}}\right)$$

When using tantalum or electrolytic capacitors. The ESR dominates the impedance at the switching frequency. For simplification, the output ripple can be approximated to:

$$\Delta V_{OUT} = \frac{V_{OUT}}{f_s \times L} \times \left(1 - \frac{V_{OUT}}{V_{IN}}\right) \times R_{ESR}$$

The characteristics of the output capacitor also affect the stability of the regulation system. The TD1464 can be optimized for a wide range of capacitance and ESR values.

PCB Layout Guide

1. Input MLCC capacitor should be connected to the VIN pin and the GND pin as close as possible.
2. Keep sensitive signal traces such as trace connecting FB pin away from the VOUT pins
3. Make the current trace from SW pin to inductor to the GND as short as possible.
4. Pour a maximized copper area to the GNDs pin and the VIN pin to help thermal dissipation

Package Information

SOP-8 Package Outline Dimensions

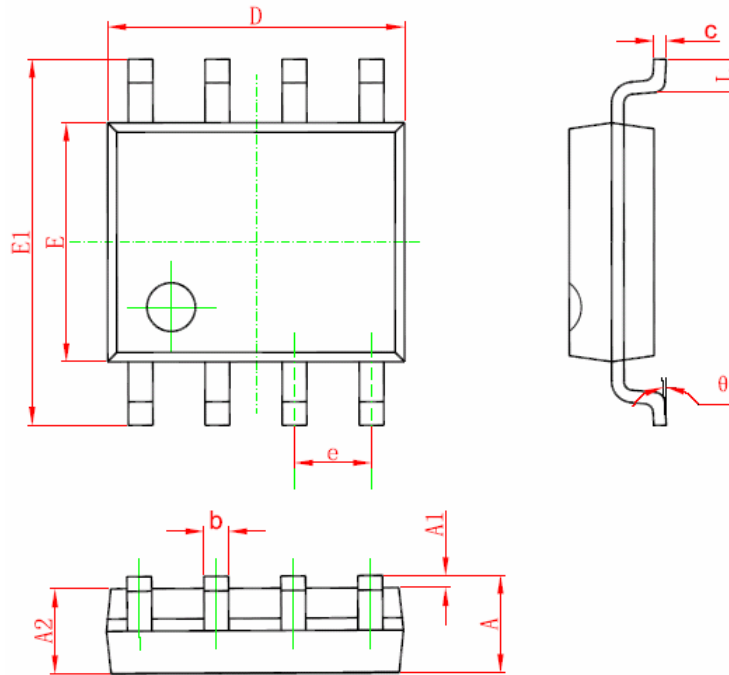

Symbol	Dimensions In Millimeters		Dimensions In Inches	
	Min	Max	Min	Max
A	1.350	1.750	0.053	0.069
A1	0.100	0.250	0.004	0.010
A2	1.350	1.550	0.053	0.061
b	0.330	0.510	0.013	0.020
c	0.170	0.250	0.006	0.010
D	4.700	5.100	0.185	0.200
E	3.800	4.000	0.150	0.157
E1	5.800	6.200	0.228	0.244
e	1.270 (BSC)		0.050 (BSC)	
L	0.400	1.270	0.016	0.050
θ	0°	8°	0°	8°

Design Notes